

# 装箱工作站

Parallel packing workstation

公司地址: 深圳市宝安区福海街道和平社区荔园路恺辉茂工业园厂房  
东莞分部: 广东省东莞市大岭山镇连平村莞长路20号力桑工业园A1栋  
24小时服务热线: 400-061-8288  
电话: 0769-82936692  
网址: [www.warsonco.com](http://www.warsonco.com)  
[www.warsonco.com.cn](http://www.warsonco.com.cn)

Add: Kaihui Maoye Industry Area, Liyuan Road, Fuhai, Baoan District, Shenzhen  
Dongguan Branch: Zone A, Lisang Industrial Park, No. 20, Guanchang Road, Lianping, Dongguan, Guangdong  
24-hour service hotline: 400-061-8288  
Tel: 0769-82936692  
Web: [www.warsonco.com](http://www.warsonco.com)  
[www.warsonco.com.cn](http://www.warsonco.com.cn)

深圳市华盛控科技有限公司  
Shenzhen Warsonco Technology Co.,Ltd.

# 董事长寄语

## Message from the chairman

目前，全球处于工业4.0发展时期，以机器人技术为代表的智能装备产业正蓬勃兴起，中国已成为全球最大工业机器人应用市场。

面对智能时代带来的机遇和挑战，我们华盛控始终坚持以创新为本，专注于智能机器人技术研发与应用，努力为客户提供满足其个性化需求的高品质智能定制产品——这是我们不变的承诺。

我们感恩时代的馈赠，也一直在思考和探索，能为这个时代多做些什么？成为中国智能机器人行业的智造先锋，为推动“中国制造”向“中国智造”转型升级的梦想贡献我们的力量，就是我们的目标。

不畏挑战，创造未来。我们始终怀着诚信之心，与合作伙伴风雨同舟，共谋发展，致力成为“全球最具有竞争力的智能机器人科技企业”。

智，无止境；华盛控，矢志前行。

At present, the world is in the development period of Industry 4.0, the intelligent equipment industry represented by robotics technology is booming, and China has become the world's largest industrial robot application market

In the face of the opportunities and challenges brought about by the intelligent era, we warsonco have always insisted on innovation, focusing on the development and application of intelligent robot technology and striving to provide all customers with high-quality intelligent customized products that meet their individual needs - this is our unchanging commitment.

We are grateful for the gift of the times, and have been thinking and exploring what more we can do for this era. To be the pioneer of intelligent robotics in China and to contribute to the dream of transforming and upgrading from "Made in China" to "Intelligent Manufacturing in China" is our goal.

We will not be afraid of challenges and create the future. We are committed to becoming "the most competitive intelligent robotics company in the world".

Wisdom, no end; Warsonco, determined to move forward.

# CONTENTS

<b>企业概况</b> Company Profile	01
<b>发展历程</b> Development History	03
<b>企业荣誉</b> Enterprise Honor	05
<b>软袋装箱机</b> Soft-bag Packaging Machine	07
<b>开装封一体机</b> Erecting, Packing And Sealing All-in-one Machine	11
<b>开装一体机</b> Erecting And Packing Integrated Machine	13
<b>装箱机适应范围</b> Scope Of Application Of Packing Machine	15
<b>合作伙伴</b> Partners	19

## 企业概况

Company Profile

深圳市华盛控科技有限公司成立于2011年，是一家机器人及相关产品的研发、生产、销售为一体的国家级高新技术企业。是以工业机器人为核心技术，国际一流的，自动化方案提供商。我们的产品涵盖并联机器人、全系列协作机器人、工业视觉及机器人控制系统等系列，广泛应用于医药、3C、食品、印包、日化等多个行业领域。

从立足中国，到迈向全球。华盛控始终以客户为中心，以专业的工匠精神，为客户量身定制独一无二的全产业链机器人科技研发解决方案，成为机器人行业应用中的典范。产品出口欧美、中东、东南亚等50多个国家和地区。

持续发展，以卓越的品质、价值和服务满足客户的需求，尊重社会和自然环境，成为让员工引以为荣的企业。

Established in 2011, Shenzhen Warsonco Technology Co.,Ltd. is a national high-tech enterprise that integrates research and development, production, and sales of robots and related products. Warsonco Technology is a world-class automation solution provider with the core technology focusing on industrial robot. Our products cover parallel robots, full series of collaborative robots, industrial vision and robotic control systems etc., and the products are widely used in various fields such as pharmaceuticals, 3C, food, printing and packaging, and daily chemical industry.

From taking the footprint in China to moving globally now, Warsonco Technology has always been client-centered. With high standard professionalism, customized the unique tailor-made R&D solution for industry chain robots, becoming a model for the application of industrial robots. Our products are exported to more than 50 countries and regions such as Europe, America, Middle East and Southeast Asia.

By focusing on sustainable development, excellent quality, value and service to meet clients' needs, while respecting the society and natural environment, Warsonco Technology is becoming an enterprise that makes employees proud of being a member.

50<sup>+</sup>

产品出口50多个国家和地区

Products are exported to more than 50 countries and regions

180<sup>+</sup>

华盛控科技累积各项专利80多项，其他各项荣誉100多种。

Warsonco Technology has accumulated more than 80 patents and over 100 other honors

4600<sup>+</sup>

累积服务客户4600多家。

Cumulatively served over 4,600 clients

# 发展历程 Development History

并联改变世界，协作成就未来。华盛控始终致力于机器人的核心技术和智能应用，为推动“中国制造”走向“中国智造”的进程持续贡献我们的力量！

Parallel (robots) changes the world, and collaborative (robots) achieves the future. Warsonco Technology has always been committed to the core technology and intelligent applications of robots and continuously contributes to the change from "Made in China" to "Intelligent Manufacturing in China"!

- 深圳市华盛控科技有限公司成立，在科学技术升级化发展的大潮中诞生；
- Shenzhen Warsonco Technology Co., Ltd. was established.
- It was born in the tide of scientific and technological upgrading;

2011

- 并联DELTA机器人，六轴机器人相继面世；
- 产品全面推向市场并获得金球奖等多项荣誉；
- DELTA robots, six-axis robots launched successively;
- The products have been fully marketed and won many honors such as Golden Globe Award;

2014-2015

2012-2013

- 国际水准科研团队专注于工业机器人本体和运动控制器研发领域；
- 推出DELTA机器人及机器人控制系统和应用软件；
- International level scientific research team focuses on the field of research and development of industrial robot body and motion controller;
- Introduce DELTA robot and robot control system and application software;

2016-2018

- 第三代并联机器人研发成功并投入市场，获得多项产品专利；
- DELTA机器人名列行业前五榜单；
- The third generation parallel robot has been successfully developed and put into the market with many patents awarded;
- DELTA robot ranks among the top five in the robot industry;

- 华盛控创新升级，隆重推出第四代并联机器人；产品远销欧美、中东、东南亚等50多个国家和地区。
- 同年开始研发并联装箱工作站及大负载协作码垛机器人。
- Warsonco Technology upgraded its innovation, launched the fourth generation of parallel robot; Our products are exported to more than 50 countries and regions in Europe, America, Middle East and Southeast Asia.
- In the same year, the Top Load Case Packer and Heavy-Load Cobot Palletizer Were developed.

2019

- 产品持续优化升级，完成全系列协作码垛机器人平台，并稳定批量应用于医药、食品、印包、日化等多个行业。
- Our products are continuously optimized and upgraded to complete the whole series of collaborative stacking robot platform, and stable batch application in many industries such as pharmaceuticals, food, packaging and daily chemical industry.

2021

2020

- 率先推出并联装箱工作站和码垛工作站。
- Warsonco Technology was the first to launch Top Load Case Packer and Palletizing Workstation.

2022

- 并联机器人出货量行业第一；
- 大负载协作机器人出货量行业第一。
- No. 1 in the industry for parallel robot shipments;
- No. 1 in the industry for shipments of heavy-load collaborative robots.

2023

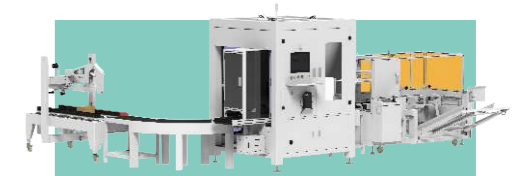

# 企业荣誉

## Enterprise Honor

华盛控坚持重技术、优服务，在高精机器人领域潜心研究，致力于掌握机器人控制核“芯”技术，已经取得80多项国家专利，为不同行业的企业量身定制更精准、更智能、更优质的智能产品和全自动智能生产解决方案。

Warsonco Technology adheres to technology and excellent service, devotes itself to researching in the field of high-precision robotics and is committed to mastering robot control core "core" technology. It has obtained more than 80 national patents, customizing more accurate, smarter and better-quality intelligent products and full-automatic intelligent production solutions for enterprises in different industries.



发明专利：16项  
Patent inventions

软件产品：7款  
Software products

软件专利：24项  
Software patents

实用新型专利：33项  
Utility model patents

外观设计专利：11项  
Appearance design patents

创新比赛荣誉：49项  
Honor and prizes in Innovation Competition

社会和行业认可荣誉：58项  
Social and industry recognized honors



# 标准软袋装箱机 WSC-ZX-RD80T / -RD80B

## Standard soft-bag packaging machine

采用自主设计高速柔性并联机器人做抓取运动，保证了产品在高速抓取搬运过程中不掉落，广泛应用于快消食品、肉制品等软袋及盒装产品进行自动识别、整理、分拣、搬运及装箱工作。

整机结构设计精密、紧凑，零配件少，容易保养及维修，维护成本费用低。占地空间小，可设在狭小的空间内工作，提高了场地使用效率。

控制方式采用手持示教器+标准控制按钮+信号开关，操作简单，方便管理。

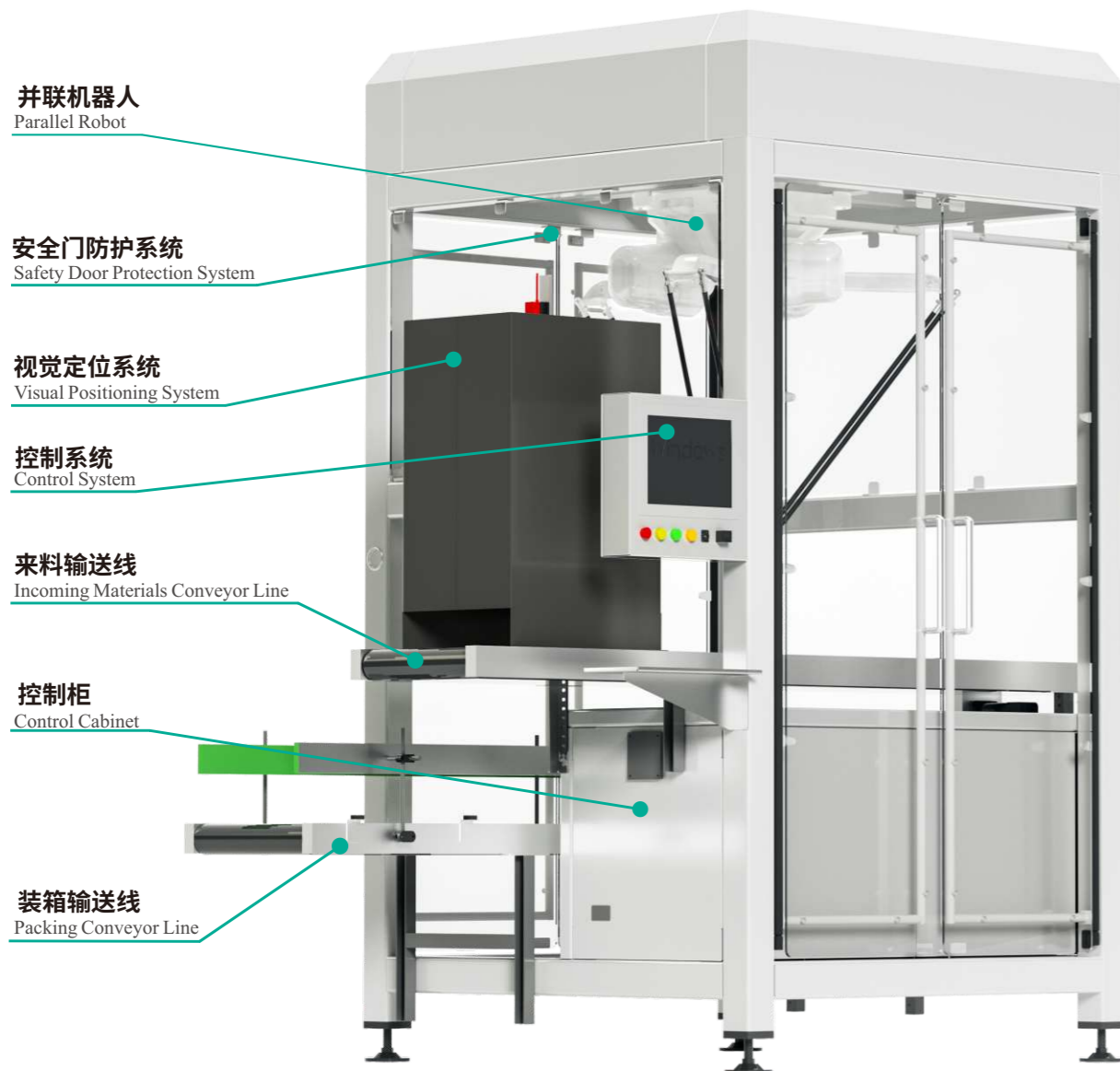

### 规格参数 Specification

项目 Items	明细 Detail
适用的产品尺寸 Applicable product size	L (10-400) mm*W (10-350) mm*H (5-100) mm
适用纸箱尺寸 Applicable carton size	L (100-480) mm*W (10-400) mm*H (100-300) mm
适用行业 Applicable industries	药品、日化、食品等行业 Pharmaceuticals, daily chemical, food and other industries
装箱速度 Packing speed	单机器人60次/分钟 Single robot: 60 times/min
主体材质 Main material	主框架: Q235烤漆(白色)/SUS304
最大功率(KW) Max Power	7kw
额定负载 Machine dimension	3kg/8kg/12kg(含抓手/with robot gripper)
外形尺寸 Machine dimension	L2630mm*W1500mm*H2360mm
配合机器人 Collaborative robot	WSC-1200D
整机重量 Machine weight	1000kg



#### 产品适用尺寸范围

L: 10mm~400mm  
W: 10mm~280mm  
H: 5mm~100mm

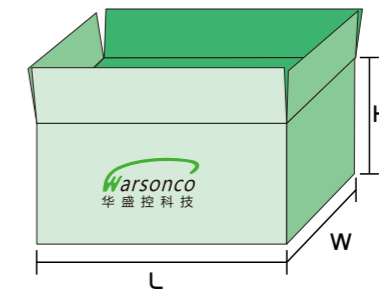

#### 纸箱适用尺寸范围

L: 100mm~480mm  
W: 100mm~400mm  
H: 150mm~300mm

### 主要配置 Advantages of Collaborative Palletizer

主要配置 Main configuration	品牌 Brand
伺服 Servo motor	PANASONIC/INOVANCE/WARSONCO
减速机 Reduce	日本新宝/绿的 JAPAN/SHIMPO
控制系统 Control system	奥地利KEBA Austria KEBA
气动系统 Pneumatic system	AirTAC

# 高速软袋装箱机 WSC-ZX-RD160T / -RD160B

## high speed soft-bag packaging machine

采用自主设计高速柔性并联机器人做抓取运动，保证了产品在高速抓取搬运过程中不掉落，广泛应用于快销食品、肉制品等软袋及盒装产品进行自动识别、整理、分拣、搬运及装箱工作。

整机结构设计精密、紧凑，零配件少，容易保养及维修，维护成本费用低。占地空间小，可设在狭小的空间内工作，提高了场地使用效率。

控制方式采用手持示教器+标准控制按钮+信号开关，操作简单，方便管理。

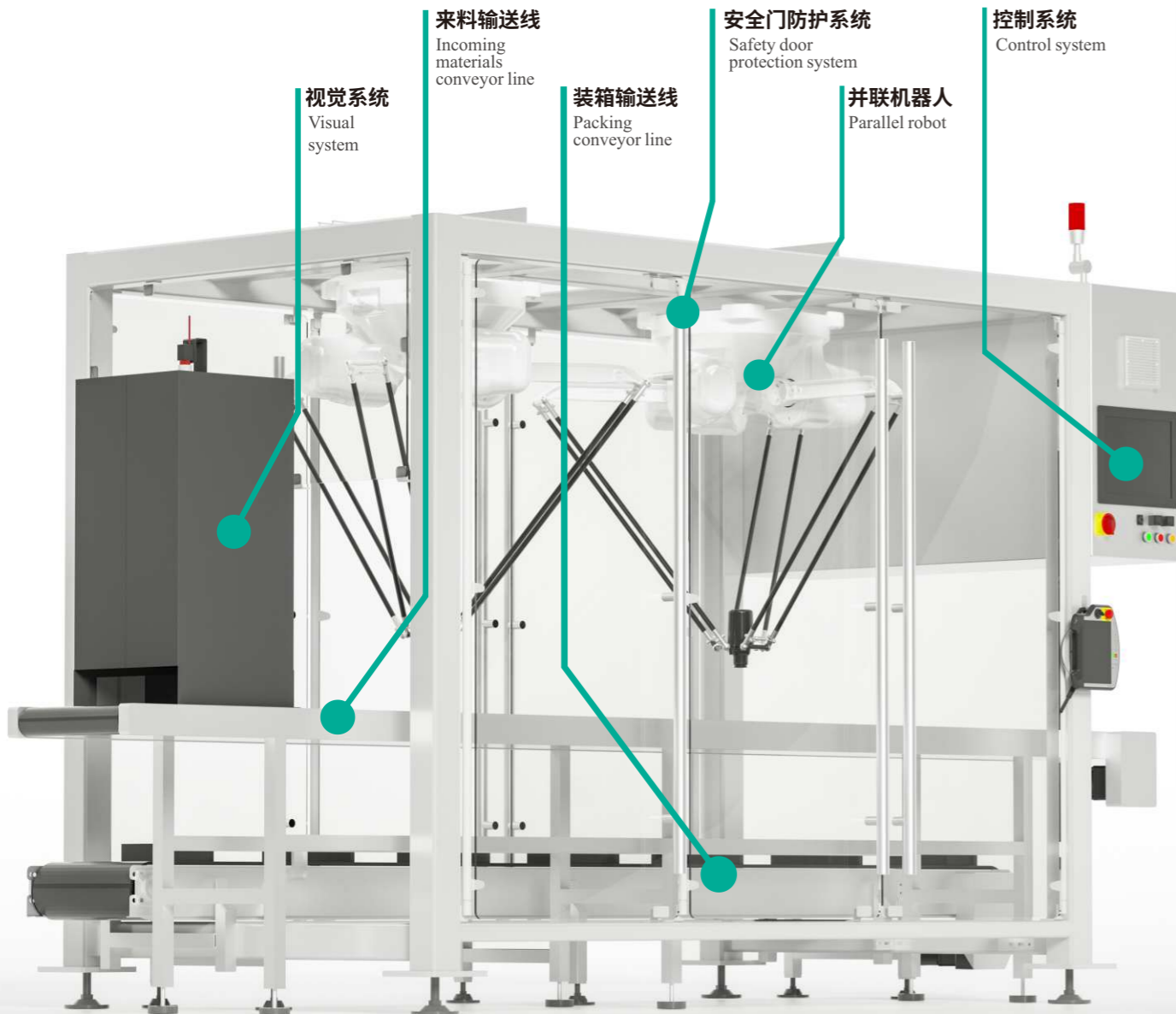

### >>> 规格参数 Specification

项目 Items	明细 Detail
适用的产品尺寸 Applicable product size	L (10-400) mm*W (10-350) mm*H (5-100) mm
适用纸箱尺寸 Applicable carton size	L (100-480) mm*W (10-400) mm*H (100-300) mm
适用行业 Applicable industries	药品、日化、食品等行业 Pharmaceuticals, daily chemical, food and other industries
装箱速度 Packing speed	单机器人60次/分钟 Single robot: 60 times/min
主体材质 Main material	主框架: Q235烤漆(白色)/SUS304
最大功率(KW) Max Power	15kw
额定负载 Machine dimension	3kg/8kg/12kg(含抓手/with robot gripper)
外形尺寸 Machine dimension	L4000mm*W1500mm*H2360mm
配合机器人 Collaborative robot	WSC-1200D
整机重量 Machine weight	1600kg



#### 产品适用尺寸范围

L: 10mm~400mm  
W: 10mm~350mm  
H: 5mm~100mm

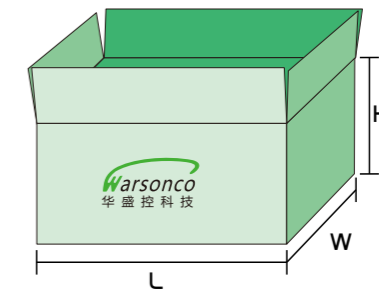

#### 纸箱适用尺寸范围

L: 100mm~480mm  
W: 100mm~400mm  
H: 150mm~300mm

### >>> 主要配置 Advantages of Collaborative Palletizer

主要配置 Main configuration	品牌 Brand
伺服 Servo motor	PANASONIC/INOVANCE/WARSONCO
减速机 Reduce	日本新宝/绿的 JAPAN/SHIMPO
控制系统 Control system	奥地利KEBA Austria KEBA
气动系统 Pneumatic system	AirTAC

# 开装一体机 WSC-KZ-RD60T / -RD60B

## Integrated machine

该设备集开箱、装箱功能为一体，安装使用简单。整机结构紧凑，集成度高，占地面积小，同时具有自动化程度高、装箱速度快、安全性高等特点。特别适合食品、医药等行业应用。

采用先进的控制技术，极大的提高设备的灵活性。通过配方管理以及可视化的设计，可灵活设置多套不同的包装方案，一键切换，极大的缩短产线换线时间，提高工作效率。

The equipment integrates the functions of erecting, packing and sealing, and is simple to install and operate. The machine is characterized by compact structure, high integration, small footprint, high automation, fast packing speed and high safety. Especially suitable for food, pharmaceuticals and other industries.

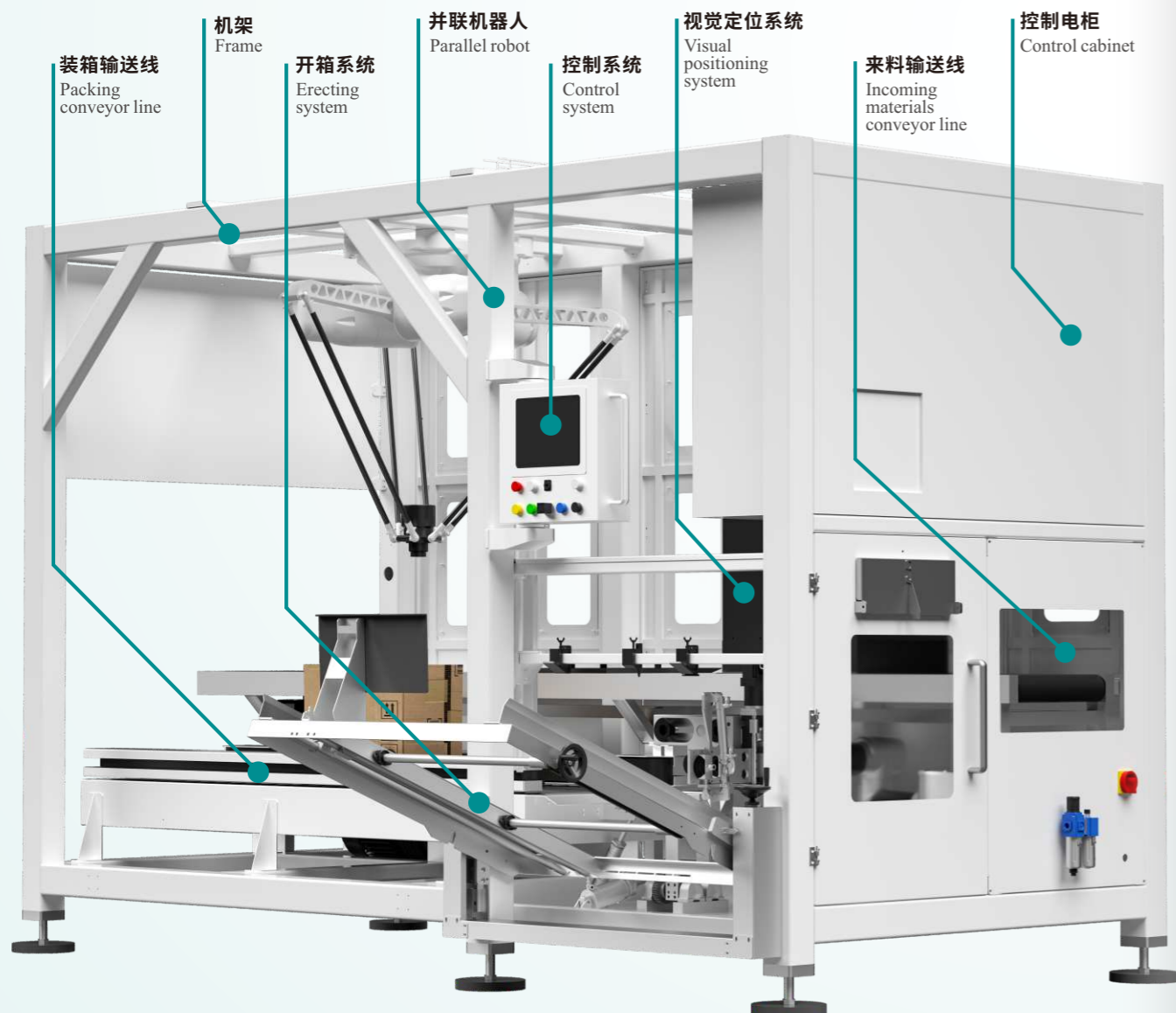

### 规格参数 Specification

项目 Items	明细 Detail
适用的产品尺寸 Applicable product size	L (10-400) mm*W (10-350) mm*H (5-100) mm
适用纸箱尺寸 Applicable carton size	L (100-480) mm*W (10-400) mm*H (100-300) mm
成箱速度 Case erecting speed	最大10箱/分 Up to 10 cases/min
适用行业 Applicable industries	药品、日化、食品等行业 Pharmaceuticals, daily chemical, food and other industries
装箱速度 Packing speed	单机器人60次/分钟 Single robot: 60 times/min
主体材质 Main material	主框架:Q235烤漆(白色)/SUS304
最大功率(KW) Max Power	12kw
额定负载 Machine dimension	3kg/8kg/12kg(含抓手/with robot gripper)
外形尺寸 Machine dimension	L2350mm*W1730mm*H2360mm
配合机器人 Collaborative robot	WSC-1200D
整机重量 Machine weight	1000kg



#### 产品适用尺寸范围

L: 10mm~400mm  
W: 10mm~280mm  
H: 5mm~100mm

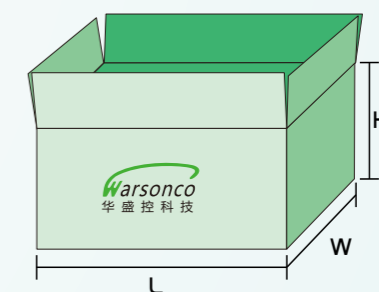

#### 纸箱适用尺寸范围

L: 100mm~480mm  
W: 100mm~400mm  
H: 150mm~300mm

### 主要配置 Advantages of Collaborative Palletizer

主要配置 Main configuration	品牌 Brand
伺服 Servo motor	Panasonic/INOVANCE/WARSONCO
减速机 Reduce	日本新宝/绿的 JAPAN/SHIMPO
控制系统 Control system	奥地利KEBA Austria KEBA
气动系统 Pneumatic system	AirTAC



# 开装封一体机 WSC-KZF-RD60T / -RD60B

## Erecting, Packing and Sealing All-in-one Machine

该设备集开箱、装箱、封箱三种功能为一体，安装使用简单。整机结构紧凑，集成度高，占地面积小，同时具有自动化程度高、装箱速度快、安全性高等特点。特别适合食品、医药等行业应用。

采用先进的控制技术，极大的提高设备的灵活性。通过配方管理以及可视化的设计，可灵活设置多套不同的包装方案，一键切换，极大的缩短产线换线时间，提高工作效率。

The equipment integrates three functions of erecting, packing and sealing, and is simple to install and operate. The machine is characterize by compact structure, high integration, small footprint, high automation, fast packing speed and high safety. Especially suitable for food, pharmaceuticals and other industries.

The use of advanced control technology greatly improves the flexibility of the equipment. Through recipe management and visual design, multiple sets of different packaging schemes can be flexibly set up. With one-click switching, it can greatly reduce the time for line changeover, thus improving work efficiency.

### 规格参数 Specification

项目 Items	明细 Detail		
适用的产品尺寸 Applicable product size	L (10-400) mm*W (10-350) mm*H (5-100) mm		
适用纸箱尺寸 Applicable carton size	L (260-500) mm*W (250-450) mm*H (150-400) mm		
成箱速度 Case erecting speed	最大10箱/分 Up to 10 cases/min		
适用行业 Applicable industries	药品、日化、食品等行业 Pharmaceuticals, daily chemical, food and other industries		
装箱速度 Packing speed	单机器人60次/分钟 Single robot: 60 times/min		
主体材质 Main material	主框架: Q235烤漆(白色)/SUS304		
额定负载 Machine dimension	5kg/8kg/12kg (含抓手/with robot gripper)		
最大功率 (KW) Max Power	15kw	配合机器人 Collaborative robot	WSC-1200D
外形尺寸 Machine dimension	L4189*W2678*H2600mm	整机重量 Machine weight	1800kg

视觉定位系统  
Visual positioning system

控制系统  
Control system

机架  
Frame

开箱系统  
Erecting system

机器人装箱系统  
Robot packing system

封箱系统  
Sealing system

# 协作装箱机

## WSC-ZX-XZ25

### high speed soft-bag packaging machine

五轴协作装箱机为本公司自主研发设计的产品，应用范围广、占地面积小，性能可靠，操作简便。适合应用于柔性包装系统，大大缩短了包装周期时间。能广泛应用于饮料、医药、食品等行业的各种产品的自动装箱。

整机部件包含:协作机器人本体、人机控制界面不锈钢装箱滚筒线、固定底座、撑箱机。

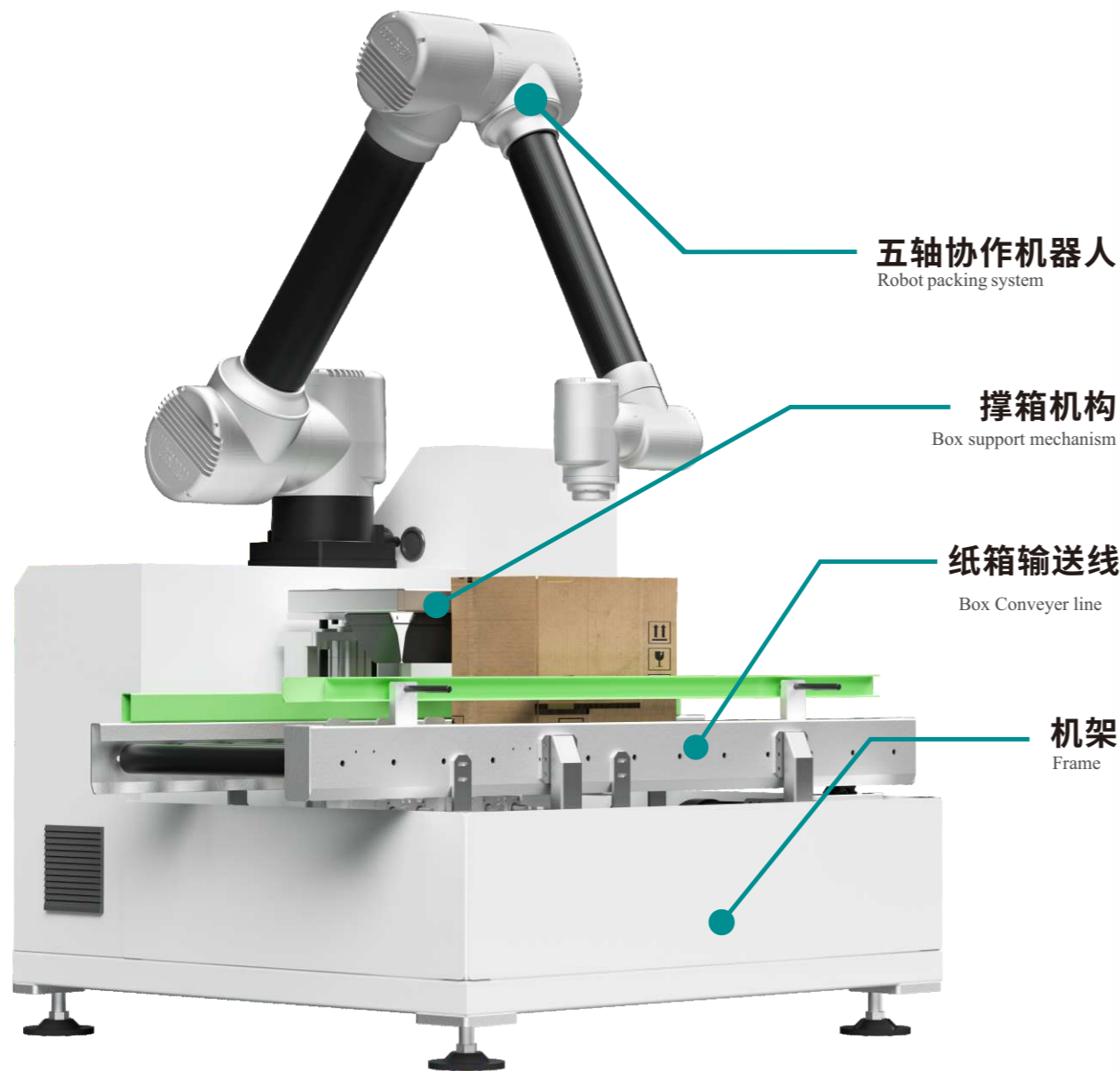

### >>> 规格参数 Specification

项目 Items	明细 Detail
适用的产品尺寸 Applicable product size	L (50-300) mm*W (50-280) mm*H (35-100) mm
适用纸箱尺寸 Applicable carton size	L (280-500) mm*W (150-400) mm*H (150-400) mm
适用行业 Applicable industries	药品、日化、食品等行业 Pharmaceuticals, daily chemical, food and other industries
装箱速度 Packing speed	6-8次/分 6-8 cases/min
主体材质 Main material	主框架:Q235烤漆(白色)
最大功率(KW) Max Power	3.5kw
额定负载 Machine dimension	25kg (不含抓手/with out robot gripper)
外形尺寸 Machine dimension	L1635mm*W1244mm*H2020mm
配合机器人 Collaborative robot	WSC-XZ30
整机重量 Machine weight	1000kg



#### 产品适用尺寸范围

L: 50mm~300mm  
W: 50mm~280mm  
H: 35mm~100mm

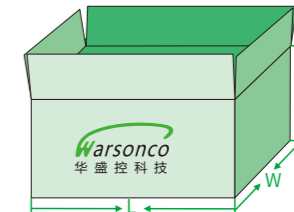

#### 纸箱适用尺寸范围

L: 280mm~500mm  
W: 150mm~400mm  
H: 150mm~400mm

### >>> 主要配置 Advantages of Collaborative Palletizer

主要配置 Main configuration	品牌 Brand
伺服 Servo motor	PAYNEW / WARSONCO
减速机 Reduce	来福 LAIFUAL
控制系统 Control system	WARSONCO
气动系统 Pneumatic system	AirTAC

# 协作开装一体机 WSC-KZ-XZ16 / -XZ20

## high speed soft-bag packaging machine

协作开装一体机是集取箱、成型、折盖、封底、装箱为一体的自动化设备，无需人工辅助，可提高生产线的自动化程度且提高生产效率。

整机部件包含：装箱协作机器人本体、人机控制界面、不锈钢装箱滚筒线、固定底座、撑箱机构、碳钢烤漆机身、气动与电气控制系统、协作开箱机器人纸板储料槽、料架宽度调节、压板高度调节、吸纸板吸盘组件、输出纸箱皮带宽度调节、纸箱底部成型机构、底部封胶机构等。

### >>> 规格参数 Specification

项目 Items	明细 Detail		
适用的产品尺寸 Applicable product size	L (50-300) mm*W (50-280) mm*H (35-100) mm		
适用纸箱尺寸 Applicable carton size	L (280-500) mm*W (250-400) mm*H (150-400) mm		
成箱速度 Case erecting speed	6-8箱/分 6-8 cases/min		
适用行业 Applicable industries	药品、日化、食品等行业 Pharmaceuticals, daily chemical, food and other industries		
主体材质 Main material	主框架: Q235烤漆(白色) / SUS304		
额定负载 Machine dimension	16kg/20kg (含抓手/with robot gripper)		
最大功率 (KW) Max Power	8.2kw	配合机器人 Collaborative robot	WSC-XZ16 / WSC-XZ20
外形尺寸 Machine dimension	L2970*W3420*H1850mm	整机重量 Machine weight	1800kg

机器人装箱系统  
Robot packing system

撑箱机构  
Box support mechanism

缓存理料机构  
Cache sorting mechanism

开箱机器人  
Robot packing system

控制系统  
Control system

开箱系统  
Erecting system

平推式料架  
Flat push type rack

# 并联装箱案例展示

Parallel packing case presentation



食品行业:饼干装箱整线  
Quick-freezing industry: Food industry: biscuit packing line



农化行业:后段装箱码垛整线  
Veterinary medicine industry: final packing and palletizing line



烘焙行业:蛋糕装箱整线  
Baking industry: cake packing line



医药行业:分拣装箱整线  
Pharmaceutical industry: sorting and boxing line

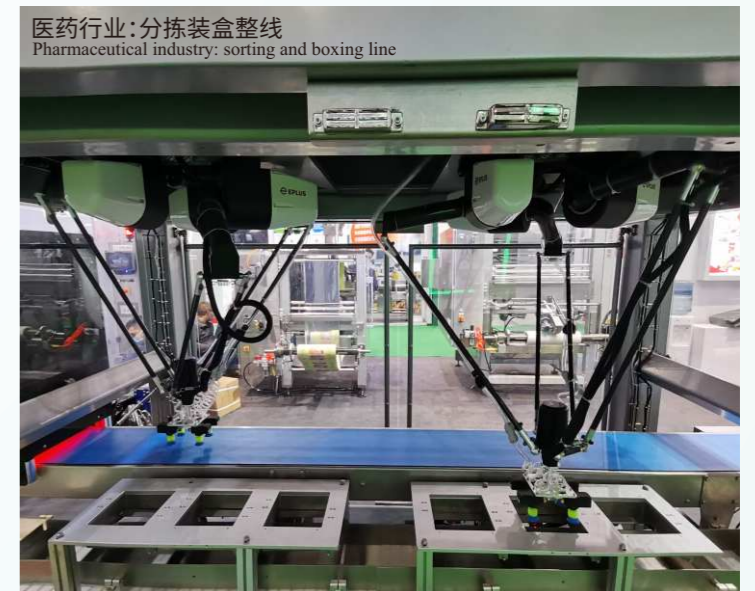

# 协作装箱案例展示

Parallel packing case presentation



牛奶行业:后段装箱码垛整线  
Veterinary medicine industry: final packing and palletizing line

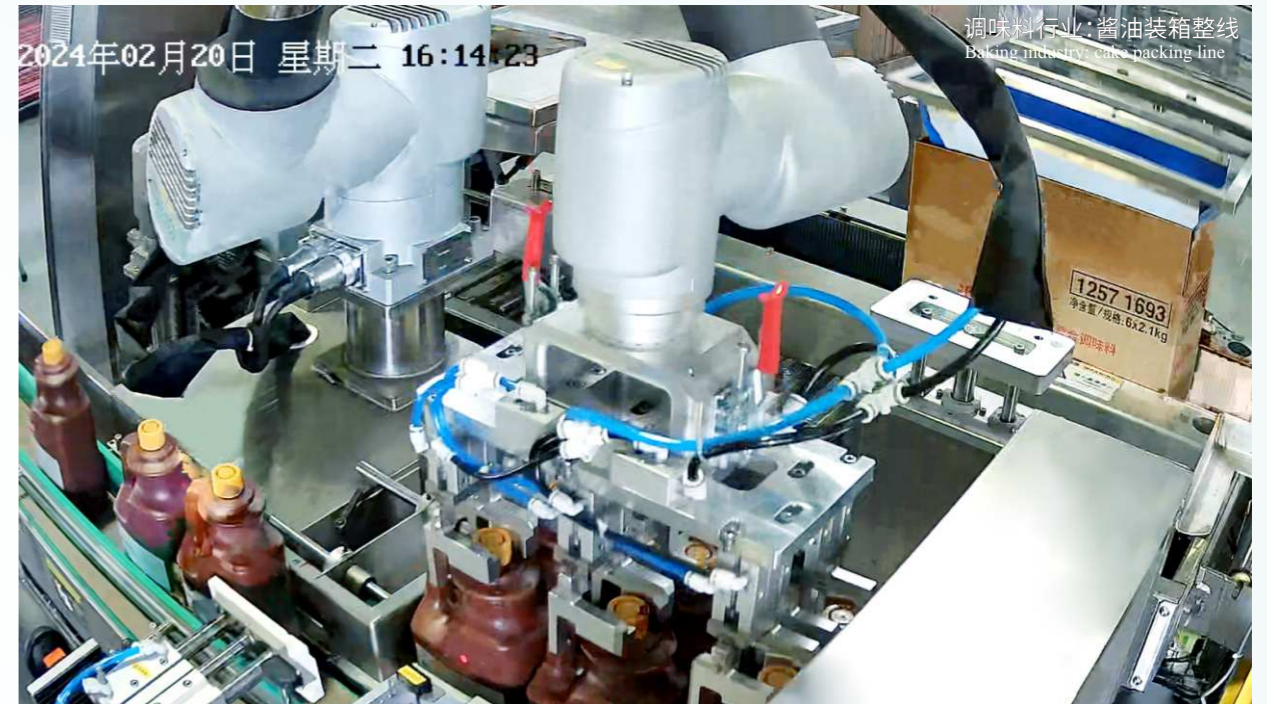

调味品行业:酱油装箱整线  
Baking industry: cake packing line

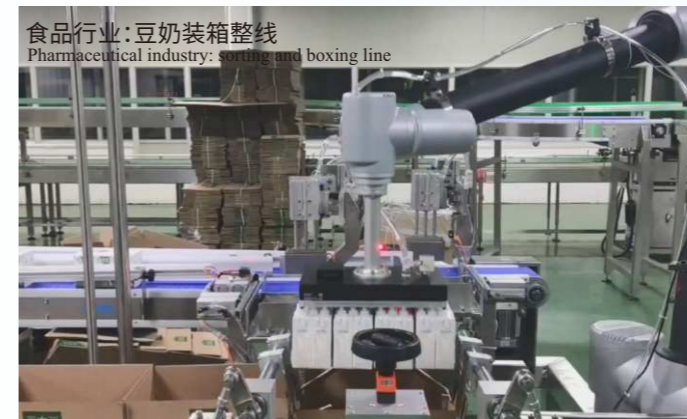

食品行业:豆奶装箱整线  
Pharmaceutical industry: sorting and boxing line



日化行业:干纸巾装箱整线  
Pharmaceutical industry: sorting and boxing line



# 合作伙伴

Cooperating partners



WEGO 威高



Kraft Heinz



今麦郎



卡士 CLASSY-KISS



PROYA 珀莱雅

立白



专注海洋美食



NESCAFÉ



您也可以像他们一样信赖我们

服务全国及海外超过70个城市4000+企业

You could trust us as much as our customers do

We serve 4000+ enterprises in more than 70 cities in China and in the world